

QINGDAO HERACLES MACHINERY MANUFACTURING CO., LTD
 Dazeshan Industrial Zone, Pingdu, Qingdao China
 Tel / Facetime/Whatsapp: 0086 17667512816
 Email: manager@heracleschina.com Facebook: 18618260514
 Name: Amelia
 www.heracleschina.com



H180 Wheel Loaders



Thanks to compact dimensions and excellent control, Heracles Wheel Loaders cannot only work in many grounds, but also tackle different problems. The hydraulic drive system makes operation more comfortable and easier. Operators can learn how to use the machines much more quickly. The individual wheel motor gives an excellent ground clearance that can make machines to be operated in restricted areas. Reliability, durability and low maintenance makes wheel loaders a good investment.

1. The Compact dimension is available for agriculture, industry and construction and so on. It is also able to deal with a lot of issues.
2. The engine performance of the hydraulic drive system is very high.
3. The designation of machines guarantees the service life and eliminates wear and tear.
4. Different operations concentrate on one handler, so it is easy to operate for you.

Technical specifications

Operating data

Payload kg	1000kg
Vehicle weight: T	2
Working system pressure: Mpa	16Mpa
Hydraulic Tank Capacity: L	30
Diesel Tank Capacity : L	30
Lifting time: s	5
L x W x H mm	4125×1150×215
Bucket Capacity:	0.3m ³

Engine / Motor

Make	Yanmar	Kubota
Model	3TNV88F-BSSY	V1505-E4B-CWL
Capacity	litter 1.642	1.495
Aspiration	Natural	Natural
Engine Performance KW	19.6KW	18.5KW
Engine RPM	2200rpm	2300rpm
Gross torque rating :	99~107.8	92.6
Discharge	China stage3	Tier4&StageV

Dimensions

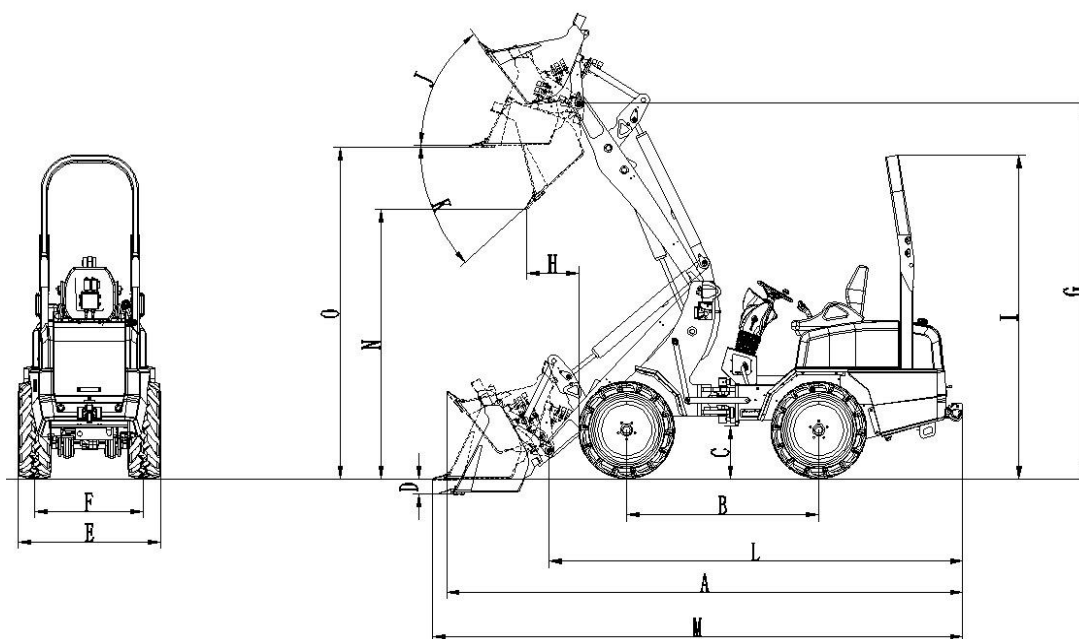

		standard wheels	Wide wheels
A	Overall Length: mm	4125	4125
B	Wheel Base: mm	1530	1530
C	Minimum Ground Clearance: mm	415	470
D	Digging depth: mm	200	145
E	Total wheel width: mm	1150	1440
F	Wheel center distance: mm	870	1004
G	Maximum lifting height of boom: mm	2950	3000
H	Discharge distance	417	360
I	Vehicle height : mm	2150	2200
J	Retracting angle	51°	51°
K	Discharge angle	45°	45°
L	Vehicle length (Without bucket) : mm	3300	3300
M	Vehicle length (With bucket) : mm	4300	4300
N	Discharge height: mm	2070	2125
O	Loading height: mm	2615	2670
	Tires	10. 0/75-15. 3	400/60-15. 5
	Tire width: mm	264	400
	Turning angle	45°	45°
	Maximum Travel Speed: KM/h	18	18
	Gradeability:	30%	30%
	Max Turning Angle of the Bucket	±90°	±90°

Please note: that product availability can vary from country to country. It is possible that information / products may not be available in your country. More detailed information on engine power can be found in the operator's manual; the stated power may vary due to specific operating conditions. Subject to alterations and errors excepted. Applicable also to illustrations.

Copyright © 2019 HERACLES SE.